

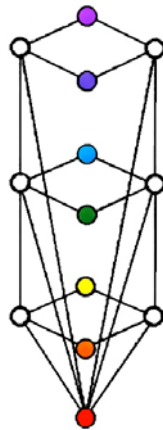

Universal Language

Ascension Reiki- 3rd Degree

(The Feeling Body)



Right Speech/Right Direction

“Listen and understand. What goes into one's mouth does not make a person clean or unclean, but what comes out of the mouth, that is what makes one clean or unclean.”

“Don't you see that whatever goes into the mouth goes into the stomach and then out of the body? But the things that come out of the mouth come from the heart.” (Yeshua- Bible- Matthew- 15:10&17)

III. The Third Degree Attunement of Ascension Reiki Attunes the Feeling Body and deepens the flow of Reiki through the Feeling Body and the Chakra System of the Feeling Body. The Seven Chakras on the Spine are connected to the Governing Vessel or Sushumna. The Five Chakras on the Front are connected to the Conceptual Vessel or Hara.

1. Acting Body (Moola Bandha Chakra)
2. Thinking Body (Uddiyana Bandha Chakra)
3. Feeling Body (Jalandhara Bandha Chakra)
4. Karmic Body (Antahkarana Bandha Chakra)
5. Mind Chakra
6. Soul Chakra
7. Spirit Chakra
8. Will Chakra
9. Higher Self Chakra
10. Sacred Heart Chakra

Chakras of the Feeling Body

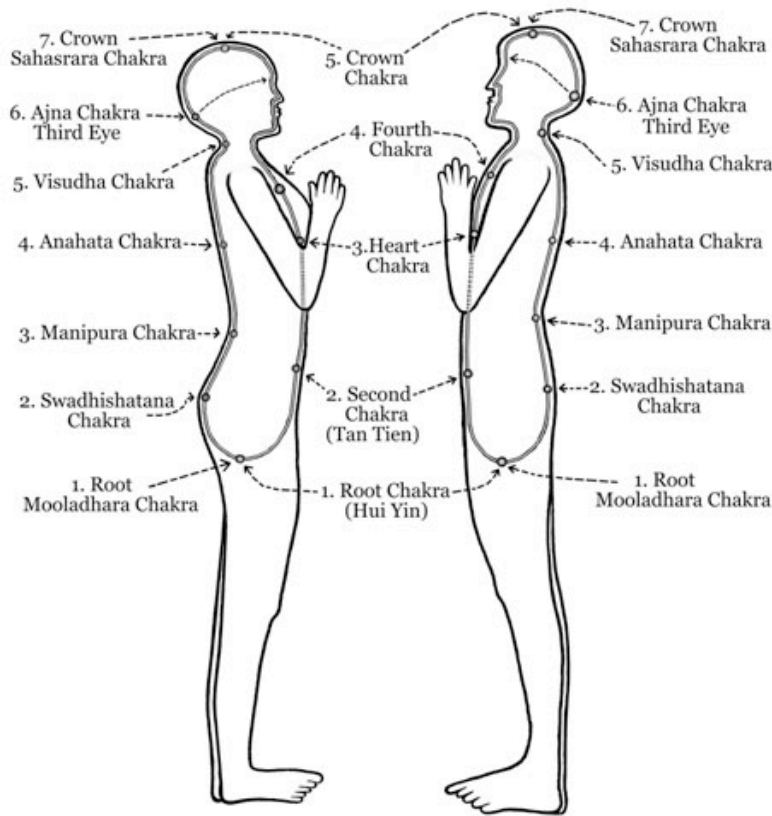

| <i>Five Front Chakras</i> | <i>Seven Back Chakras</i> |
|--|---|
| 1. Hui Yin 2. Tan Tien 3. Heart Chakra 4. Forth Chakra 5. Crown Chakra | 1. Muladhara Chakra 2. Swadhishatana Chakra 3. Manipura Chakra 4. Anahata Chakra 5. Visudha Chakra 6. Ajna Chakra 7. Sahashaha Chakra |

A-U-M

The Self as the universal person in dreamless sleep, corresponds to the third letter- M (The Feeling Body and its 12 energies)

Kabbalah

Symbol of the 12 Spiritual Energies of The Feeling Body

The Tree of Life Symbol has been around for thousands of years. There are different forms of this symbol, each having different layers of understanding and interpretation. Each view of Kabbalah is an insight into the depth of understanding the mysteries of Our One Creator and Creation itself. Kabbalah is a type of Mandala for Meditation and Contemplation. All the versions of the symbol have several things in common but each inspires us to be open minded and open hearted. There is no one version that is more correct than another but each represents a way of feeling God.

- Each is an "Archetypal Representation" at one or more levels.
- Each is composed of Spheres and pathways of energy connecting the Spheres
- Each has three columns of Spheres. (Left-Yin)(Central-Core)(Right-Yang)

The Kabbalah Tree of Life



http://mytapestry.crosswinds.net/tree_of_life.html

The Kabbalah- Tree of Life

The word 'Qabala' finds its root in the Hebrew word 'Qibel' meaning 'to receive by oral tradition'.

This receiving refers to an oral tradition of esoteric or secret knowledge concerning 'essentially' the mysteries of Nature, and more overtly, the hidden teachings concerning the Hebrew Torah. The Torah is, of course, the first five books of what Christians call the Old Testament, and the oldest surviving of the Judaic liturgical texts.

The Kabala is an ancient Hebrew mystical system of thought. It is a symbolic representation of the path the Divine followed in the creation of the universe, including man. It is, by definition, humanity's process of returning to divinity along the same path.

Kabbala, also spelled KABALA, KABBALAH, CABALA, CABBALA, OR CABBALAH, is an esoteric Jewish mysticism as it appeared in the 12th and following centuries. Kabbala has always been essentially an oral tradition in that initiation into its doctrines and practices is conducted by a personal guide to avoid the dangers inherent in mystical experiences.

Esoteric Kabbala is also "tradition" inasmuch as it lays claim to secret knowledge of the unwritten Torah (divine revelation) that was communicated by God to Moses and Adam. Though observance of the Law of Moses remained the basic tenet of Judaism, Kabbala provided a means of approaching God directly. (The quote above, the three color pictures and the explanation of the Ten Spheres below from <http://www.crystalinks.com/kabala.html>

The Ten Sephiroth of the Kabbalah Tree of Life

(Ten Spheres)

(The Columns)
Yin--Equilibrium--Yang

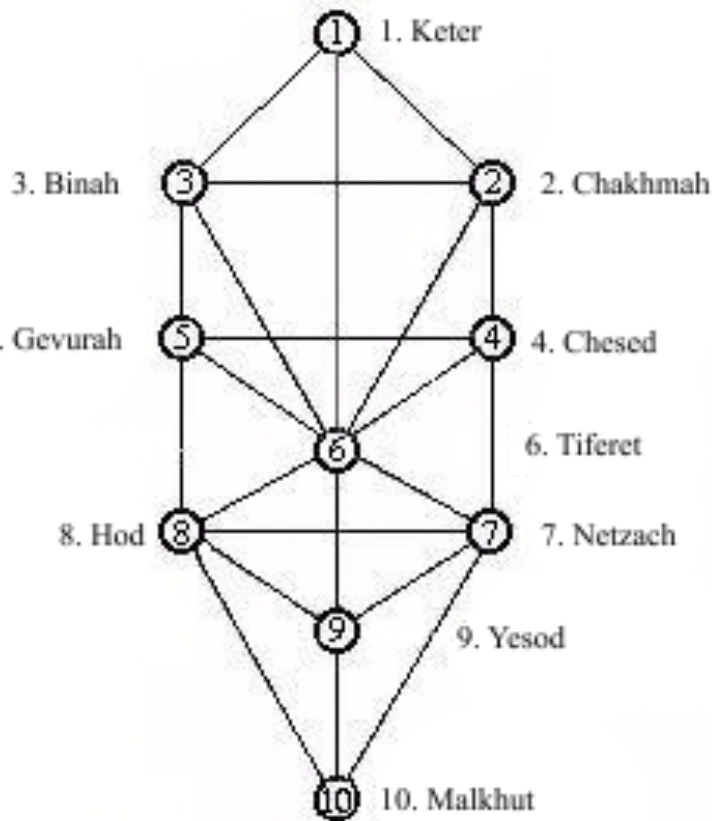

(Kabbalah and Hebrew Letters)

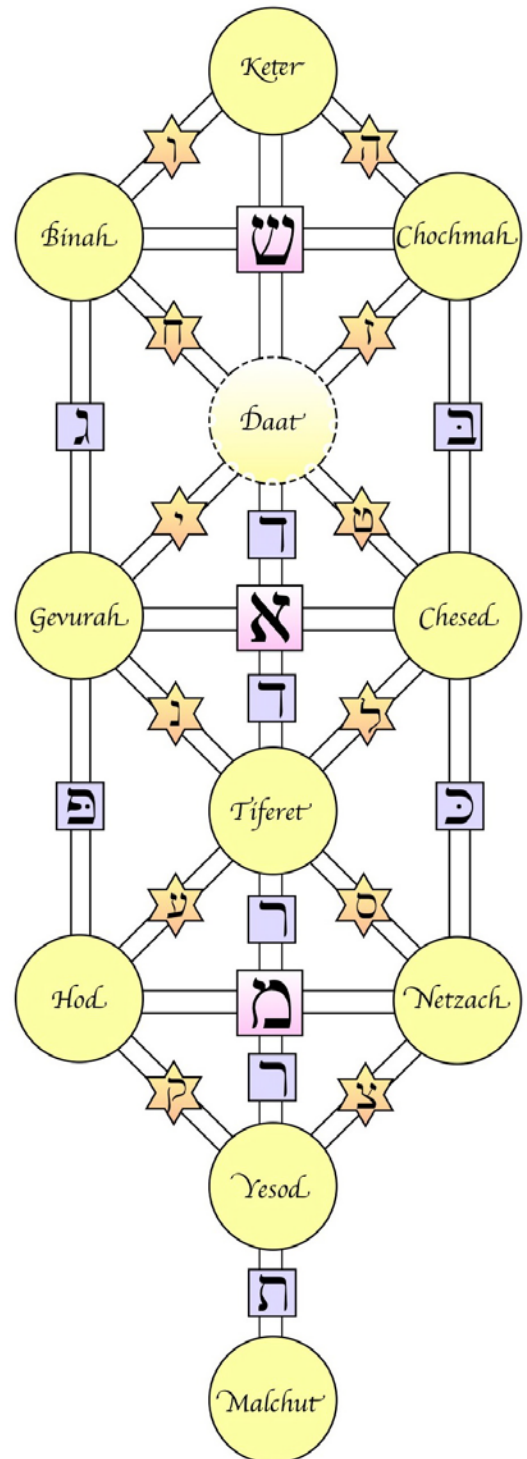

The Energetic Anatomy Tree of Life

(Formulated by Caroline Myss, PH.D)

The Tree of Life is a symbolic diagram, which has been used by Kabbalists (Judaism's most ancient mystical sect) for several thousand years. It explains how energy flows down from God into the world.....

The ten sefirot are arranged in a way that divides them into seven levels. Each of these levels corresponds perfectly with those of the chakra and sacrament systems, and represents a quality of power that is essential for us to develop in order to maintain a healthy body - both physically and spiritually.

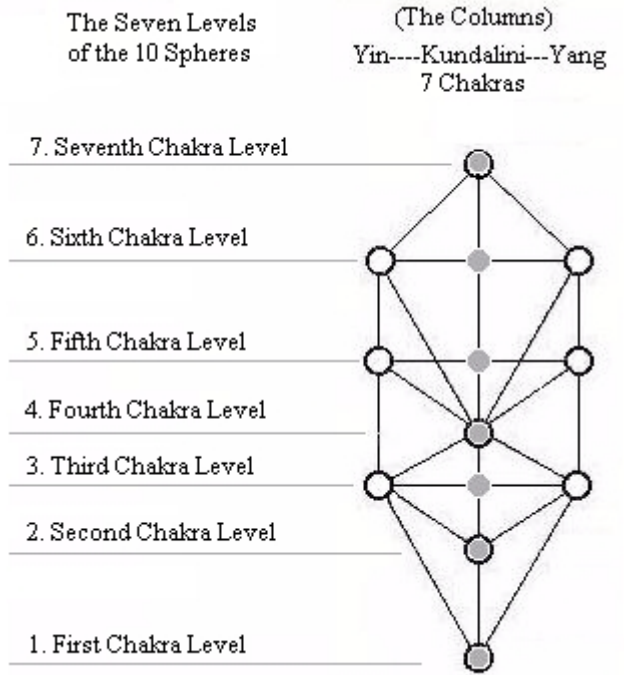

Layers of Understanding the Tree of Life

The Three Bodies

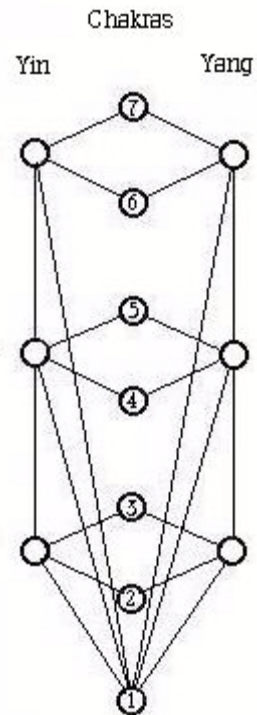
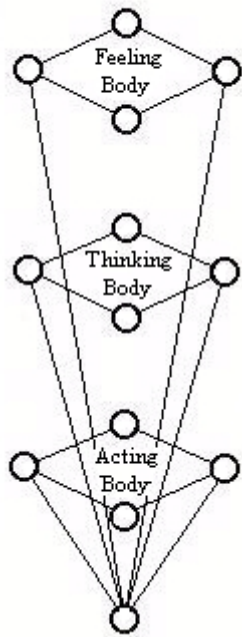

The Three Planes

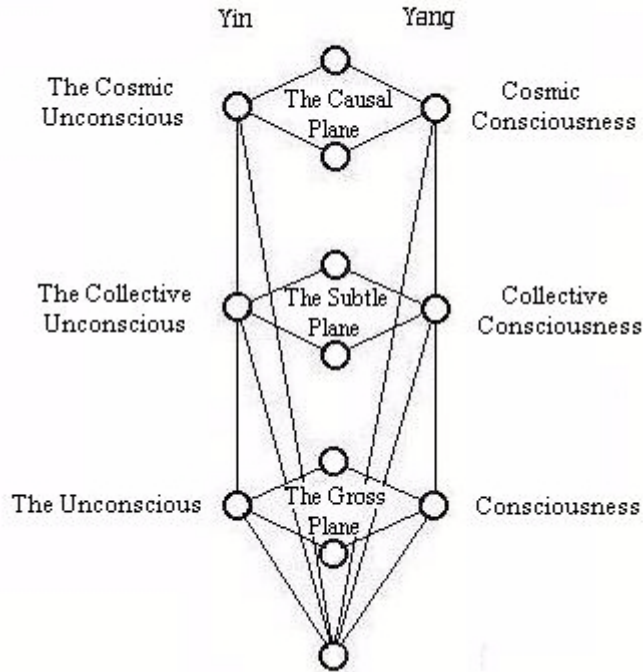

The Tree of Life Symbol has many levels of meaning. It has meaning as a two dimensional as well as three dimensional Symbols.

| The Main Chord and Seven Chakras of The Atman | | | | | | | | | | | | | | | | | |
|--|---|--|---|--------|-------------------|----------------|--------------------------|-----------|--------------------|-------|-------------------------|---------|-------------------|----------|--|---------|--|
| | <p>The Kabbalah is the Symbol for the Feeling Body. The Feeling body is composed of The Seven Chakras on the Blackbody (Spine) and the Five Chakras on the Front body. There are many levels of understanding that are associated with it.</p> <table border="0"> <tr> <td>Seven Back Body Chakras Seven Spirits of the Elohim</td> <td>Five Front Body Chakras The Ascended Masters</td> </tr> </table> <table border="0"> <tr> <td>7. God</td> <td>5. I AM THAT I AM</td> </tr> <tr> <td>6. Holy Spirit</td> <td>4. Radharani and Krishna</td> </tr> <tr> <td>5. Christ</td> <td>3. Uma and Brahman</td> </tr> <tr> <td>4. OM</td> <td>2. Yasodhara and Buddha</td> </tr> <tr> <td>3. Love</td> <td>1. Mary and Jesus</td> </tr> <tr> <td>2. Faith</td> <td></td> </tr> <tr> <td>1. Hope</td> <td></td> </tr> </table> | Seven Back Body Chakras Seven Spirits of the Elohim | Five Front Body Chakras The Ascended Masters | 7. God | 5. I AM THAT I AM | 6. Holy Spirit | 4. Radharani and Krishna | 5. Christ | 3. Uma and Brahman | 4. OM | 2. Yasodhara and Buddha | 3. Love | 1. Mary and Jesus | 2. Faith | | 1. Hope | |
| Seven Back Body Chakras Seven Spirits of the Elohim | Five Front Body Chakras The Ascended Masters | | | | | | | | | | | | | | | | |
| 7. God | 5. I AM THAT I AM | | | | | | | | | | | | | | | | |
| 6. Holy Spirit | 4. Radharani and Krishna | | | | | | | | | | | | | | | | |
| 5. Christ | 3. Uma and Brahman | | | | | | | | | | | | | | | | |
| 4. OM | 2. Yasodhara and Buddha | | | | | | | | | | | | | | | | |
| 3. Love | 1. Mary and Jesus | | | | | | | | | | | | | | | | |
| 2. Faith | | | | | | | | | | | | | | | | | |
| 1. Hope | | | | | | | | | | | | | | | | | |

Another View of Kabbalah

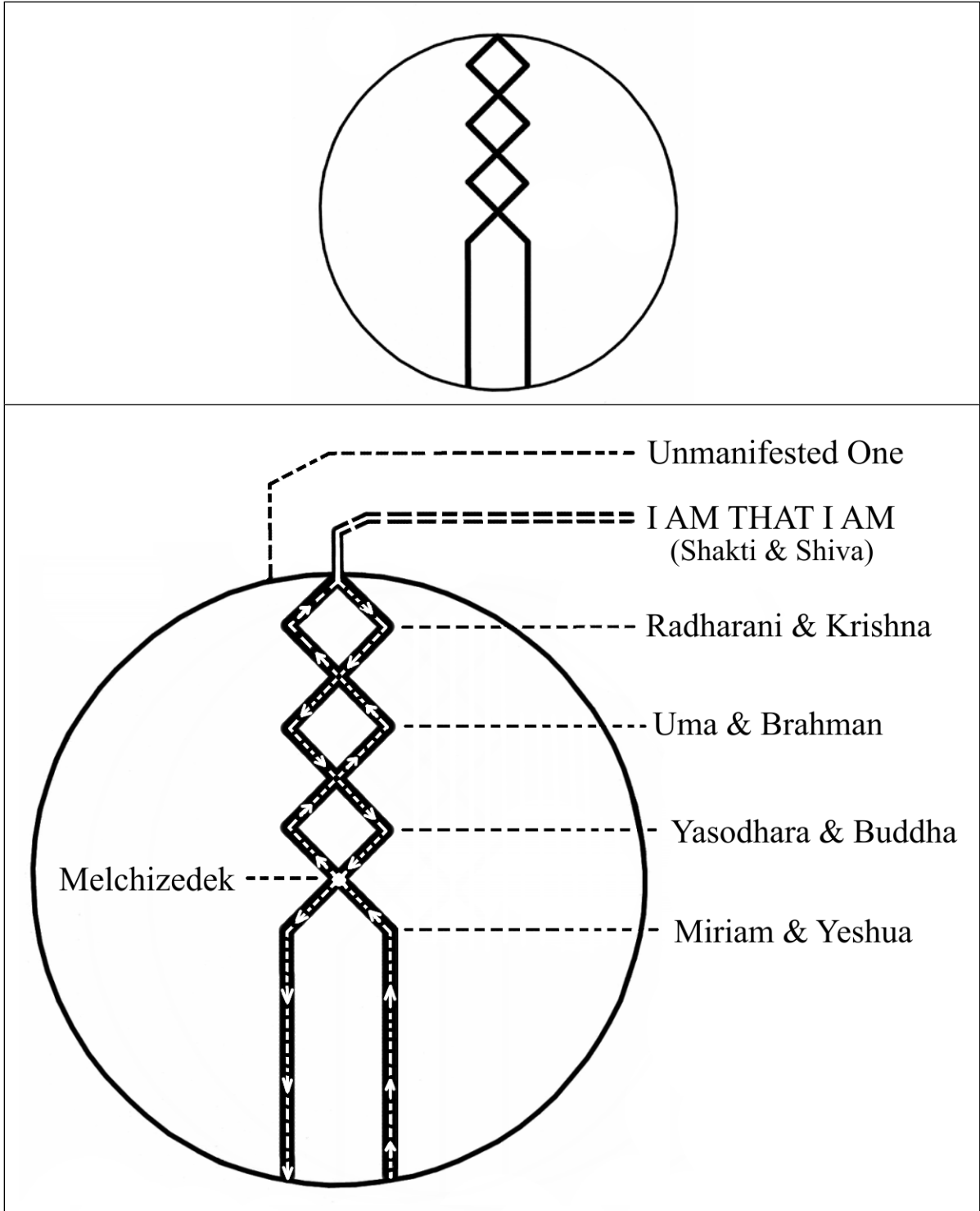

Drawing the Kabbalah - Feeling Body (Causal Body)

Draw the Kabbalah Symbol with both hands. Place the index fingers together at the top (1) and follow the arrows down to the bottom. Bring the index fingers together at the bottom of the circle and then trace the circle upward (2). This is the easy draw form of Kabbalah.

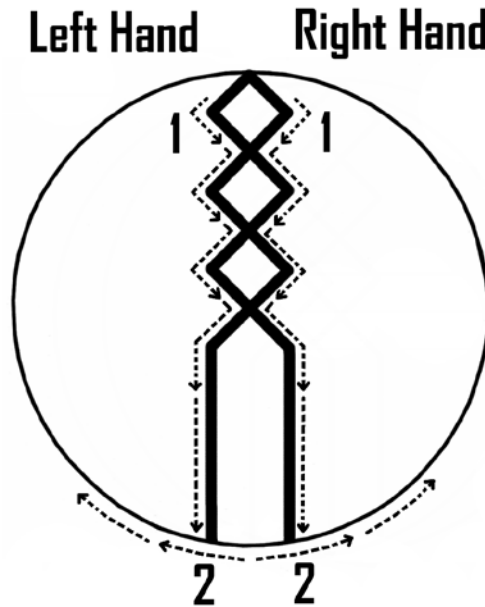

Japa Yoga- 3rd Degree

Japa Yoga- Union with God through the Names of God

Words are symbols of ideas or concepts. For instance when you think the name of a friend, a picture and a concept of that friend comes to mind. When you are in a room with that person and you speak their name they turn to you and then you are face to face. This is the nature of Japa Yoga.

When we think upon and speak the names of the Personalities of God, the Names of God there is a turning of God's presence to greet us. As we think upon the names of God and the knowledge of God's names we receive the Ki-Rays of Light and wisdom associated with them. We gradually begin to leave the mundane world behind and live in and through the Grace of God in our lives. There are many names of God that we can think upon, learn about and speak about with one another.

The Names of God

*The Names of the Personalities of God correspond with the Chakras above the head.
The Names of the Seven Spirits correspond with the Chakras from the Crown Down.*

| <i>The Personalities of the Godhead</i> | <i>Chakras Above the Head</i> | <i>The Seven Spirits of God</i> | <i>7 Chakras from the Crown Down</i> |
|---|-------------------------------|---------------------------------|--------------------------------------|
| <i>Melchizedek</i> | <i>Sacred Heart Chakra</i> | <i>God</i> | <i>7th- Sahashaha</i> |
| <i>Unmanifested One</i> | <i>Higher Self Chakra</i> | <i>Holy Spirit</i> | <i>6th- Ajna</i> |
| <i>I Am That I Am</i> | <i>Will Chakra</i> | <i>Christ</i> | <i>5th- Visudha</i> |
| <i>Radharaani/Krishna</i> | <i>Spirit Chakra</i> | <i>Om</i> | <i>4th- Anahata</i> |
| <i>Uma/Brahman</i> | <i>Soul Chakra</i> | <i>Love</i> | <i>3rd- Manipura</i> |
| <i>Yasodhara/Buddha</i> | <i>Mind Chakra</i> | <i>Faith</i> | <i>2nd- Swadhishatana</i> |
| <i>Miriam/Yeshua</i> | <i>Karmic Body Chakra</i> | <i>Hope</i> | <i>1st- Muladhara</i> |